

# TITAN™ Series

## LOW SPEED, HIGH TORQUE, RADIAL PISTON HYDRAULIC MOTORS

**WARRANTY**  
**BEST IN THE INDUSTRY!**  
**SEE OUR WEB PAGE FOR DETAILS.**



### FEATURES:

- INTERCHANGEABLE WITH FLENDER HYDRAULIC MOTORS
- MULTI-CAM LOBE DESIGN
- LARGE HOLLOW THRU-SHAFT
- 120 POWER STROKES PER REVOLUTION
- EXCEPTIONALLY QUIET RUNNING
- INTEGRAL TORQUE ARM AND COUPLING
- TANDEM MOUNTING CAPABILITY
- SUPERIOR LOW SPEED PERFORMANCE
- MULTIPLE MOUNTING CONFIGURATIONS
- VERY COMPACT
- WIDE RANGE OF ACCESSORIES
- DESIGNED FOR INDUSTRIAL DUTY APPLICATIONS
- OUTPUT TORQUE CAPACITY TO 155,000 LB. FT. INTERMITTENTLY; 124,000 LB. FT. CONTINUOUSLY

### OPTIONS:

- HOLLOW THRU-SHAFT WITH INVOLUTE SPLINES
- SOLID OUTPUT SHAFT

### ACCESSORIES:

- THRUST BEARINGS
- ENCODERS
- TORQUE ARMS
- FOOT BRACKETS
- MULT-DISC BRAKES
- BACKSTOPS
- CROSS LINE RELIEF VALVES
- POWER UNITS AND CONTROL SYSTEMS
- PLANETARY TORQUE MULTIPLIERS WITH OUTPUT TORQUES TO 1,000,000 LB. FT. OR MORE

### ***Innovative Hydraulic Designs, Inc.***

6830 North Eldridge Parkway, Unit 102  
Houston, Texas 77041 USA  
Telephone: +1 (713) 849 - 2949  
Telefax: +1 (713) 849 - 5638



[www.ihd-usa.com](http://www.ihd-usa.com)

# TITAN Hydraulic Motor • Direct Drive • Shaft Mounted • Hollow Shaft with Shrink Disc Connection

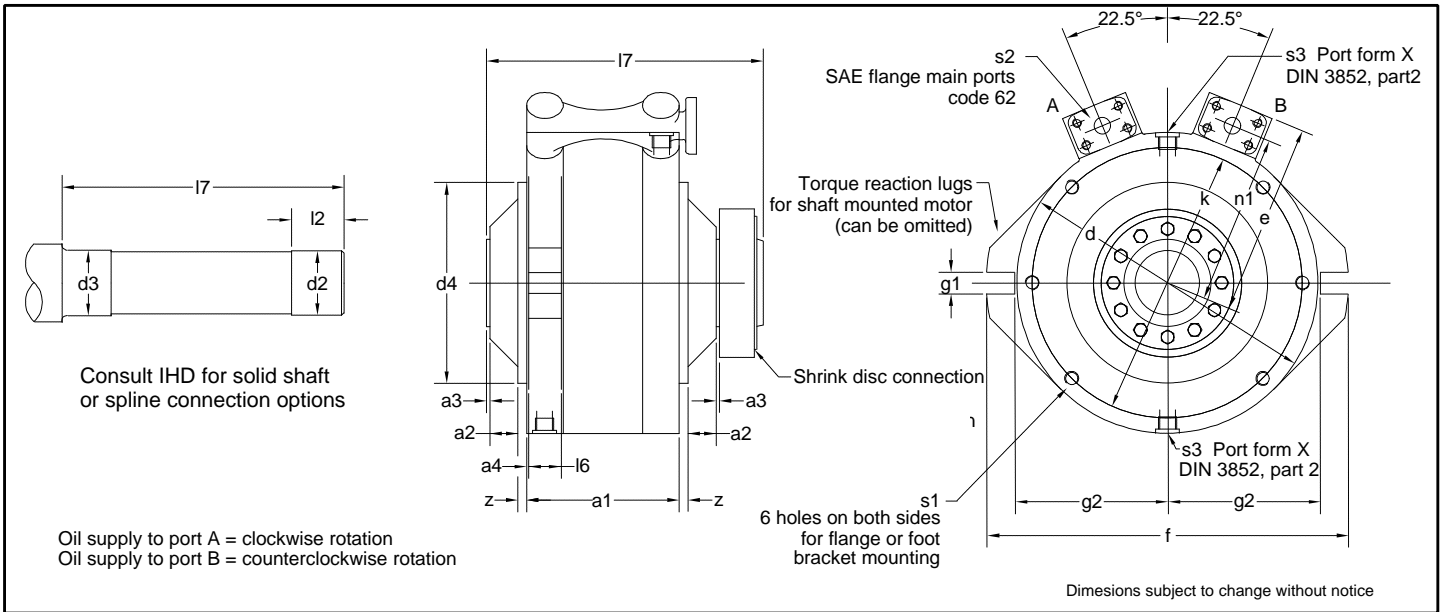

## Dimensions

Type HMS Size	a1 in.	a2 in.	a3 in.	a4 in.	d in.	d2 in.	d3 in.	d4 in.	d5 in.	e in.	f in.	g1 in.	g2 in.	k in.	l2 in.	l5 in.	l6 in.	l7 in.	n1 in.	s1 mm	s2 SAE Flange	s3 Drain Port BSPP	Z in.
345	6.89	1.26	.16	.10	13.58	2.91	2.95	9.06	6.69	8.66	16.34	.98	6.81	12.20	2.76	1.97	1.46	12.48	7.68	M16x22	¾"	G ½	.39
410	8.27	1.02	.16	.10	16.14	3.31	3.35	10.83	7.28	10.31	19.29	1.18	8.11	14.57	3.15	2.17	1.77	13.58	9.09	M16x24	1"	G ¾	.39
455	9.25	1.10	.20	.12	17.91	3.70	3.74	12.20	8.46	11.61	21.46	1.30	8.98	16.14	3.35	2.36	1.97	15.00	10.24	M20x30	1½"	G ¾	.39
515	10.43	1.18	.24	.12	20.28	4.09	4.13	13.78	9.06	13.15	24.21	1.50	10.16	18.31	3.74	2.56	2.17	16.61	11.57	M20x35	1½"	G ¾	.39
575	11.61	1.14	.24	.16	22.64	4.49	4.53	15.16	10.35	14.45	26.97	1.65	11.34	20.47	4.13	2.76	2.56	18.31	12.80	M24x40	1½"	G 1	.59
635	12.80	1.26	.28	.16	25.00	4.88	4.92	16.73	11.42	15.63	29.72	1.81	12.52	22.64	4.53	2.95	2.76	20.00	13.98	M24x45	1½"	G 1	.59
690	13.78	1.38	.28	.20	27.17	5.47	5.51	18.31	12.99	16.93	32.28	1.97	13.62	24.61	5.12	3.74	2.87	22.01	15.20	M30x45	1½"	G 1	.59
745	14.72	1.65	.28	.20	29.33	6.06	6.10	19.69	13.78	18.03	35.04	2.17	14.69	26.57	5.51	3.74	3.15	23.50	16.30	M30x50	1½"	G 1	.59
830	16.52	1.87	.28	.28	32.68	6.79	6.82	25.14	14.54	19.75	39.50	2.52	16.37	29.98	5.75	4.31	3.59	26.21	18.06	M36x55	2"	G 1¼	.59
910	18.11	2.05	.31	.31	35.83	7.44	7.48	27.56	15.94	21.65	43.31	2.76	17.95	32.87	6.30	4.72	3.94	28.74	19.80	M36x55	2"	G 1¼	.54
1000	18.61	2.51	.35	.28	39.37	8.20	8.24	29.35	17.35	23.26	47.25	3.05	19.75	35.79	5.73	4.83	3.75	30.60	21.47	M42x65	2"	G 1¼	.72
1100	20.47	2.76	.39	.31	43.31	9.02	9.06	32.28	19.09	25.59	51.97	3.35	21.73	39.37	6.30	5.31	4.13	33.66	23.62	M42x65	2"	G 1¼	.79

## Displacements, Torques, Pressures, Speed Ranges and Weights

Type: HMS Size	Displacement (in³/rev)	gal/rev	Torque Ratings (1)			Wr² (lbs./ft²)	Max Pressure PSI	Speed Range RPM	Max. Speed RPM	Weight lbs.
			lb.ft / 1000 psi	(2) Nominal (lb.ft.)	(3) Max (lb.ft.)					
345-01100	67	0.29	890	3540	4445	8.31	5000	0-160	200	230
410-01740	106	0.46	1405	5630	7035	18.91	5000	1-150	190	385
455-02625	160	0.69	2125	8505	10630	31.58	5000	1-150	190	520
515-03860	236	1.02	3125	12495	15620	58.16	5000	1-150	190	730
575-05245	320	1.39	4245	16985	21230	100.2	5000	0-140	175	1015
635-07480	421	1.82	5580	22320	27900	166.9	5000	0-120	150	1345
690-09135	557	2.41	7390	29570	36960	259.6	5000	0-100	125	1740
745-11795	720	3.12	9545	38180	47725	360.0	5000	0-80	100	2160
830-16020	978	4.23	12965	51865	64830	755	5000	0-60	75	3660
910-22230	1357	5.87	17990	71965	89960	1019	5000	0-50	65	4015
1000-27220	1661	7.19	22030	88115	110145	1720	5000	0-40	50	6215
1100-38340	2340	10.13	31030	124115	155140	2600	5000	0-32	40	6835

(1) Theoretical Values

(2) Based on 4000 psi, S.F. 1.0

(3) Maximum 10% of the duty cycle

(4) Titan hydraulic motors are also available with integral planetary torque multipliers. Request document 600.004